

# A GUIDE TO TRAPEZOIDAL SCREW JACK DESIGN, CONSTRUCTION AND SELECTION

*To obtain the highest-quality screw jack, be sure to consider the design, material quality and manufacturing, testing, certifications and the supplier.*



When you need to move a heavy load with a high degree of accuracy and safety, a trapezoidal screw jack is hard to beat. Because trapezoidal screw jacks are a well-established technology with an enduring design, you'll find many high-quality units to meet your basic design needs. It is also easy to assume that there's no difference among the many products available. However, not all screw jacks are created equal. When performance counts, some factors can make the difference between a good screw jack and an exceptional screw jack.

This article will provide an overview of some of the basic considerations to remember when you select a trapezoidal screw jack, and it will explain how screw jack design, construction, manufacturing, lubrication and other factors can help your gearbox perform at its best.



## Review the Basic Specifications

When specifying a trapezoidal screw jack, make sure you check the manufacturer's datasheet for the following information:

- **Load capacity.** Refer to the screw jack's datasheet for its static and dynamic load handling capabilities. Keep in mind that there is more to specifying a screw jack than knowing its load capacities. You will need to specify whether the screw jack will be configured for a compression or traction load.
- **Input speed.** Input rpm and gear ratios will help determine how fast the load can travel. Unimec offers standard ratios of 1:5, 1:10 and 1:30. Due to the friction that occurs between the internal gears and within the threads of the spindle, a high travel speed can overheat the unit. Using our testing machines, we have accurately calculated that trapezoidal screw jack input speeds should never exceed 1,800 rpm x 60 Hertz. Check your screw jack manufacturer's reference charts for acceptable heat limits.
- **Duty cycle.** Screw jacks require intervals between uses to dissipate heat and do not operate continuously. Duty cycle indicates the frequency at which the screw jack moves the load.
- **Other factors.** These may include environmental conditions that affect the screw jack's operation such as temperature and vibrations.

When lifting a load in compression configuration, the spindle may be susceptible to so-called buckling or deformation under the weight of the load. In this type of situation, refer to Euler's laws for guidance on how to reduce the load. In traction mode, the buckling of the spindle is negligible. Also note that screw jacks are not designed to handle lateral loads. If your load is not perfectly centered, you must use a linear bearing to absorb the moment and thus prevent premature wear or possible failure.

## An Enduring Design Versus a Fresh Approach

The traditional screw jack design consists of a metal plate supporting a rounded gearbox with a trapezoidal screw on top. Although this design is well-established, it has a drawback: To install the gearbox, it must connect directly to the metal plate and users must specify the

screw jack's orientation based on whether it will be subjected to either a compression or traction load. The flanged design also presents a potential weak point where the metal plate connects to the round section of the gearbox.

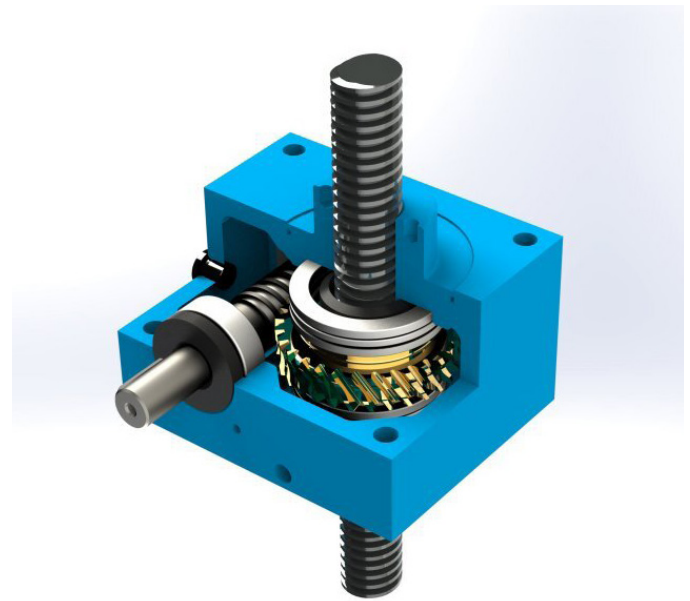

*This square gearbox design features a dual-guide with dual bearing and precision machined surfaces on all six faces, allowing the screw jack to be installed in multiple configurations.*

To obtain more orientation flexibility, consider a less conventional design. One such design not only offers orientation flexibility, but also exceptional sturdiness and easy installation. This design is characterized by a square shape and six machined surfaces, which allow the screw jack to be installed in multiple configurations. Unimec trapezoidal gearboxes feature this square design with through-holes that allow top-to-bottom installation as well as side installation.

A pair of collars — each with an integrated bearing identical to and having the same load capacity in both directions as the other — guide the spindle and eliminate the need for specifying the load direction and operating configuration. This innovative dual-guide and dual-axial bearing concept also provides inherently more precise motion since the spindle is guided by two points instead of one. The result: a single system for all configurations.



## Materials and Manufacturing

While there is little variation among screw jack manufacturers regarding the materials used in screw jack construction, some materials are more appropriate than others in certain situations. The material is also closely related to how the screw jack components are manufactured. In fact, high-quality materials in combination with superior manufacturing processes typically produce the best-performing screw jacks. Here's a summary of the various materials used in screw jack construction, their characteristics and some of the manufacturing factors that can distinguish a high-performance unit.

### Gearboxes/Frames

- **Machined aluminum.** This material is commonly used for smaller units due to its heat dissipation properties, good durability and high tensile strength.
- **GJL cast iron.** Well-suited for mid-size frames, cast iron offers excellent rigidity, durability and good damping characteristics.
- **Electro-welded S355 steel.** Carbon manganese — a non-alloy steel — is recommended for large units used in the most demanding applications. Features include high strength and excellent weldability.
- **Technopolymer.** An advanced technopolymer is not only cost-effective, it also boasts a variety of advantages. To learn more, refer to the sidebar, *Technopolymer Allows Screw Jacks to Work Dry in Food Applications.*

### Screw Jacks and Bevel Gear Reducers

- **AISI 316 stainless steel.** This widely used stainless steel offers good corrosion resistance and excellent defense against salinity as well as good tensile strength in both low and high operating temperatures.

### Internal Gears and Worm Screws

- **Tin bronze.** Known in the industry as the go-to material for gears, tin bronze can resist wear and offers some corrosion resistance, good machinability and low- to medium load capacity.
- **Aluminum bronze.** Aluminum bronze has higher tensile strength and greater wear resistance compared to generic tin bronze. Unimec's aluminum bronze

complies to EN-1982-2017 standards and obtains its properties thanks to permanent chill mold casting manufacturing. This process creates gears with a finer, more homogeneous microstructure and an inherently more accurate coupling with other gears. It also results in higher reliability over time and a longer life, plus quiet operation and excellent sliding properties.

- **Case-hardened steel.** This material is known for its ability to withstand heat treatments with minimal deformations. Worm screws made from case-hardened steel exhibit greater wear resistance and exceptional structural consistency. When a case-hardened worm screw is also cemented and precision-ground, it couples precisely to the worm wheel and is more durable.

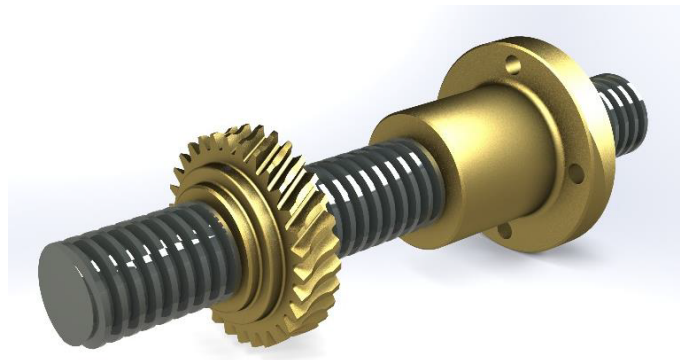

*Compared to regular tin bronze used in worm wheels and lead nuts, Unimec uses an EN-1982-2017-compliant aluminum bronze that is harder and presents a finer and more homogeneous microstructure, offering a higher tensile strength and superior wear resistance.*

### Spindles

- **C45 steel.** A medium-grade carbon steel that is typically more cost-effective than alloy steel.
- **AISI 316 stainless steel.** (See previous.)

Depending on the size of the spindle, both of these materials can be manufactured by cutting or thread rolling. Cutting typically offers good precision as well as the ability to manufacture special threads, multiple starts, left-threaded spindles or other features, but it also results in higher surface roughness. Thread rolling, however, produces a smooth, high-quality surface.



A more advanced thread rolling option — Unimec’s 3-Die thread rolling — not only produces a smoother surface than cutting, it creates a more rolling-friendly thread surface with quieter operation, reduced wear and better longevity.

Note that if your application is intended for critical operations such as in extreme environments or where human safety is essential, be sure to partner with a manufacturer that certifies its materials and is capable of meeting specific industry or regional protocols.

### Don’t Overlook Lubrication

In any system with moving parts, proper lubrication is a must. Although many gearboxes are lubed for life, the trapezoidal screw jack does require lubrication. The appropriate amount of lubricant for your spindle and the proper frequency will depend on the diameter of the screw, the stroke length and your machine’s duty cycle. If your machine will operate in a special environment, be sure to use a lubricant formulated for that environment.

Keep in mind that deploying maintenance personnel can be costly, especially if your gearboxes must operate in a hard-to-access location. A screw jack manufacturer that makes lubrication easy and helps minimize maintenance needs can add value to your screw jack investment while reducing headaches.

### Select a Screw Jack Manufacturer That Meets All Your Requirements

Although there are many screw jack manufacturers to choose from — including many that base their products on a longstanding, reliable flange-type design — not all suppliers are equal. The right screw jack manufacturer will partner with you to meet all your reliability and performance requirements. Be sure to look for the following attributes in a screw jack manufacturer:

- **Certified materials and testing.** The right screw jack manufacturer will ensure your unit is constructed to the highest integrity by using fully certified, traceable materials. It will also make certain it will perform in your intended application. Unimec, for example, goes beyond the typical simulation and uses proprietary, in-house test machinery to replicate the application by applying the same load weight, cycle, speed and

### EXPLORE YOUR LUBRICATION OPTIONS

While today’s screw jacks offer exceptional durability and strength, proper lubrication is still critical to ensuring reliable operation and good value on your investment. After all, screw jacks last a long time when properly maintained. When you choose Unimec’s proprietary lubricants, you can extend maintenance intervals up to two to four times, thereby significantly reducing your maintenance needs.

However, there are many situations that call for more than a standard lubricant or a conventional lubrication system. For example, special environments may also require special grease formulations. And, shutting down important machinery and sending maintenance personnel to harsh or remote environments is time consuming and expensive. Fortunately, the right manufacturer can help ease the burden of lubrication so you can get more out of your screw jack.

Unimec offers many lubrication options for critical applications and environments, from forced lubrication systems to single-chamber construction, oil-bath lubrication and programmable units. One such device, the CU Single Chamber Assembly — available as an option on the TP Series — is a completely sealed, oil-bath configuration for applications where the duty cycle requires constant, continuous lubrication for all moving parts. The lid is programmable, so users can input their lubrication specification.

Another option, Oil Bath Rigid Protection, protects the trapezoidal screw against dust and debris. The unit is completely sealed and is filled with oil. Every time the spindle dips down, it dips into the oil bath for permanent lubrication. For special applications, Unimec can provide non-standard lubricants for food applications, high and low temperatures, clean room and biological environments as well as nuclear applications and explosive applications.

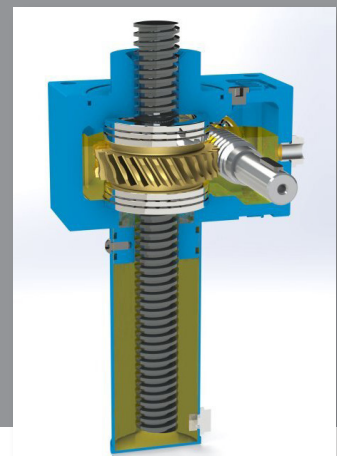

*This completely sealed, oil-bath assembly provides constant, continuous lubrication of all moving parts.*



## TECHNOPOLYMER ALLOWS SCREW JACKS TO WORK DRY IN FOOD APPLICATIONS

In today's food and beverage industry with ever-faster production and throughput goals, you can't afford maintenance downtime. However, maintaining screw jacks in food and beverage manufacturing machinery can be difficult since you cannot simply choose an off-the-shelf lubricant. Regulations require lubricants that are able to resist degradation from food products, chemicals, water and steam as well as prevent microorganism and bacterial growth. You will need to consider many variables when selecting an appropriate food-grade lubricant, and you may still have to cope with an undesirable maintenance schedule. Innovative screw jack materials and manufacturing processes can solve this dilemma.

Technopolymers are high-strength plastics that outperform conventional plastics, especially when it comes to resisting heat and mechanical stress. When reinforced with fiberglass, they offer very high strength and rigidity as well as good creep resistance. In addition to these advantages, a technopolymer can work without lubricants — a desirable trait in many food industry applications.

Unimec's Aleph Series of trapezoidal screw jacks are made from polyarylamide — a glass-fiber reinforced technopolymer. Polyarylamide's properties are well-suited for Unimec's manufacturing processes. During molding, a pure polymer film forms on the molded component surfaces, giving them excellent sliding properties. These sliding properties, along with other factors, allow the Aleph Series to operate dry. Although the technopolymer is not self-lubricating, the sliding layer of the spindle can significantly reduce maintenance downtime and even extend the screw jack's life.

Aleph Series screw jacks are cost-effective and have nearly the same mechanical functions, self-locking features and 1:5, 1:10 and 1:30 ratios as a Unimec TP trapezoidal screw jack with translating spindle and the TPR trapezoidal screw jack with rotating spindle and translating nut. For applications that undergo washdowns using harsh chemicals, Unimec also offers the X Series made completely of stainless steel.

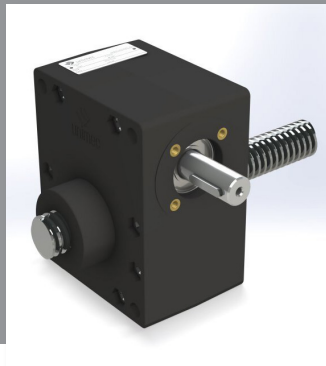

*Unimec's Aleph Series trapezoidal screw jacks are made from a fiberglass-reinforced technopolymer that gives molded component surfaces excellent sliding properties for dry operation.*

stroke, as specified, and presents the results to the customer. Not only can Unimec certify the screw jack's calculations and lifetime estimates, we can also certify that the unit is manufactured to the application's required protocols.

- **Vertically integrated production.** When you need a quality screw jack, it makes sense to partner with a supplier that controls its manufacturing processes. When a screw jack manufacturer produces its components in house, quality is assured and customization is not only easier, lead times are shorter. You'll also get a quicker response when you need to solve a problem.
- **Custom Solutions.** Although there are numerous screw jack manufacturers offering many standard products, many applications present special requirements that off-the-shelf screw jacks cannot satisfy. In these cases, a special unit is the best means of solving a problem, maximizing performance or adapting to a special environment.

## The Unimec Difference: Peace of Mind

Unimec offers all of these benefits and many more. Our trapezoidal screw jacks feature a square design with a dual-guide and the dual-axial bearing concept for sturdy, reliable, efficient and accurate operation in all load configurations — without the need to specify load direction. These irreversible units are also built to last, with completely machined finished outer surfaces and components made from high-quality, traceable and certified materials, including EN-1982-2017 aluminum bronze for the most demanding applications. In addition, we certify our screw jacks using a full roster of in-house test equipment that replicates the application. These advantages, combined with superior manufacturing processes, result in screw jacks that perform reliably over a long lifetime while meeting the most demanding and sophisticated application requirements. And, we back our products up with a standard two-year warranty.

Because we control the entire manufacturing process and supply chain from start to finish, customers can trust the quality and accuracy of our screw jacks. This vertically integrated production philosophy also allows us to create non-standard screw jacks tailored precisely to your application's unique requirements.



In fact, half the orders Unimec fulfills are “specials.” With the ability to satisfy all your screw jack needs, we are your ideal partner for any screw jack application that requires extra peace of mind.

### **Obtain Superior-Performing Screw Jacks**

Screw jack technology goes back more than 100 years, so your selection process will turn up an abundance of suppliers that create a good-quality unit — typically with the same time-tested design. When you consider a radically different design and emphasize certified quality materials along with the supplier, its manufacturing and testing processes and other factors, you can obtain highly reliable, superior-performing screw jacks and optimal value.

*For more information about Unimec trapezoidal screw jacks, visit [www.unimecusa.com](http://www.unimecusa.com).*

